



Dienst Uitvoering Onderwijs
*Ministerie van Onderwijs, Cultuur en
Wetenschap*

Introduction to open badges

**Erik van den Broek, DUO,
Groningen**

badges are not new...



- recognise skills or achievements
- visual

... not only a reward

- badges have long use as a motivation tool in many different disciplines



modern times

- digital learning environments
- digital job application
- digital student admission

(~~scanned paper diploma~~)

something new is needed

5

a digital certificate that is visual and secure

offered by a new standard:

OBI - open badge infrastructure

a common framework for the issuing,
collection, and display of digital badges

(originally developed by MacArthur and Mozilla
Foundations → non profit!)

open badge anatomy

- an image
- “baked” with data & *made unchangeable!*

- name
- description
- **issuer**
- **criteria**
- **evidence**
- {valid thru}
- *etc*



how it might look:

7



“I can solve almost all problems that arise when using digital technology. I can choose the right tool, device, application, software or service to solve (non-technical) problems. I am aware of new technological developments. I understand how new tools work. I frequently update my digital skills.”

issued by: InternationalElectro Ltd

issued to: Piet Jansen

issuing date: November 20, 2018

valid thru: November 20, 2023

what do you need?

As an organisation:
an issuing platform

(many tools/factories available)



badgr

As an earner:

a backpack / e-portfolio
(many options available)

 **badgecraft**



Backpack



Open
Badge
Passport

earner manages badges in a “backpack”⁹

Open Badge Backpack

Home Help: On

gab@shaw.com

Sign Out

mozilla

Badges



Upload Badges

If you have badges you've been awarded, you can upload them manually

Upload

Groups

Mozilla & P2PU



public

Other



public

Drag a Badge Here

earner can share it from the backpack:

❖ social media



❖ digital cv



❖ eportfolio



❖ personal blog



badge systems

Badge systems = a frame of several predefined badges used in a certain learning environment

→ standardisation increases value

Badges for EU key competences?

DigiComp



Badges for EU key competences?

CEFR





Dienst Uitvoering Onderwijs
*Ministerie van Onderwijs, Cultuur en
Wetenschap*

bridging the gap between
formal and non-formal
education?

national qualification structure for VET

15

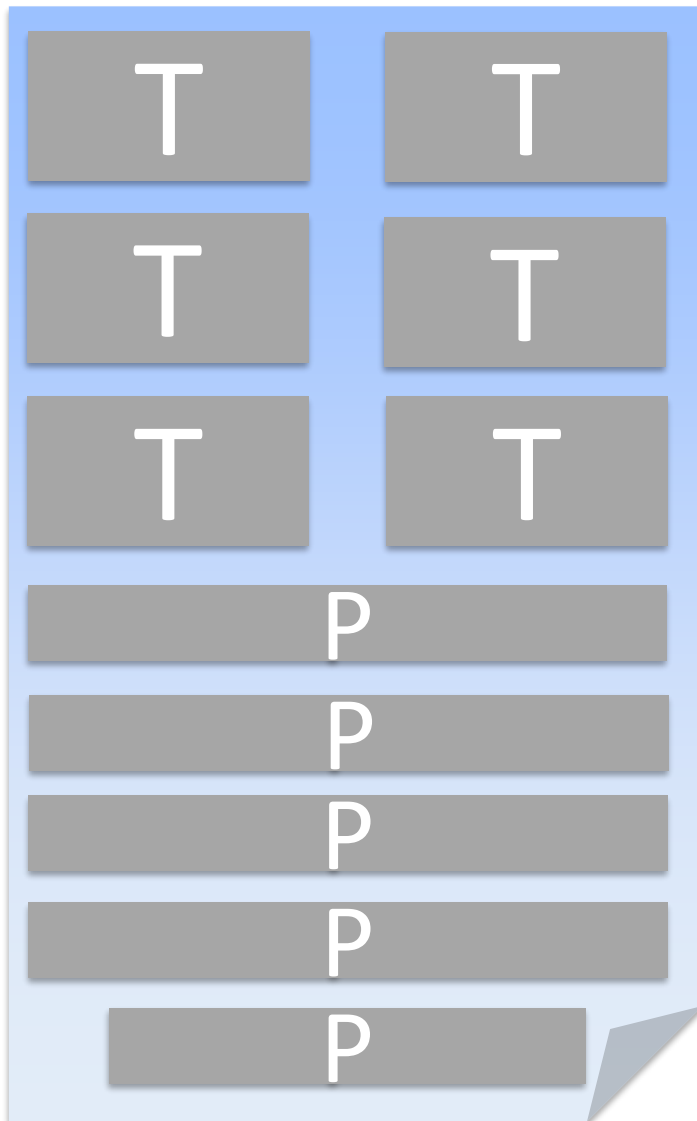

Describes the theoretical (T) and practical (P) content of all the formal VET qualifications (EQF 2-4)

dutch qualification structure for VET

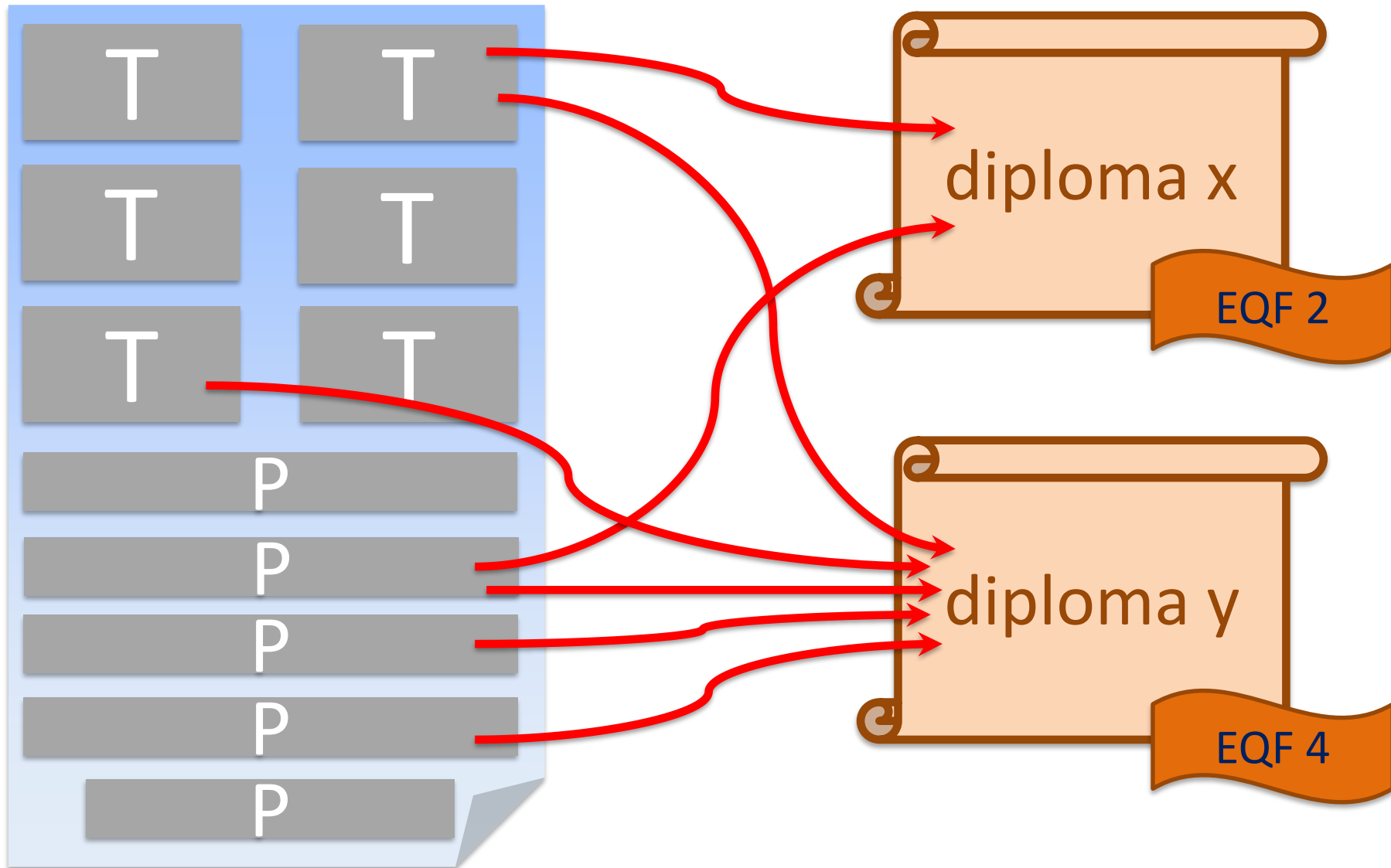

diplomas not reachable for all

- EQF-2 diploma was defined as the desired minimum level before leaving school
- but.... not everyone is able to accomplish that

a new “sub-diploma” level certificate

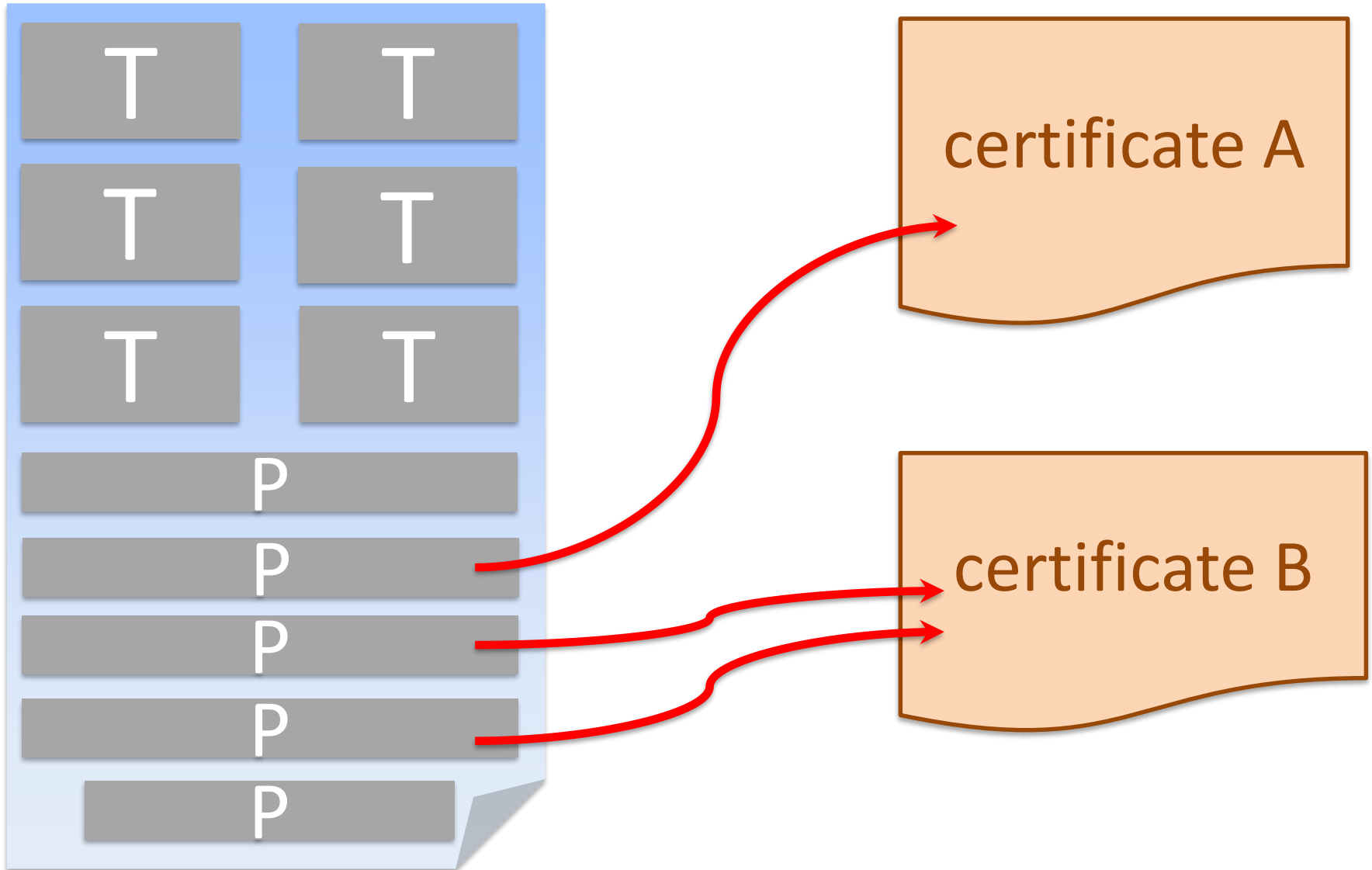

a new “sub-diploma” level certificate

- issued by company, officially recognised for workplacements
- defined as minimum level for an entry level paid job
- content of the certificate is split into smaller units → badges



etc....

learning pathway

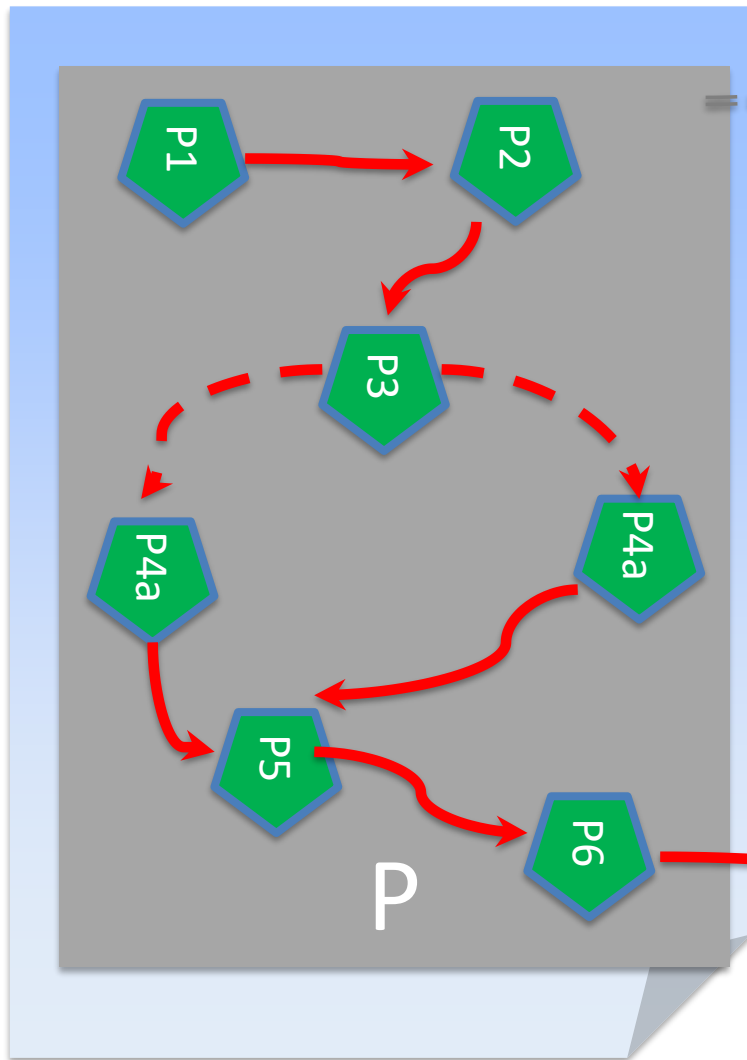

each badge describes one or more learning outcomes, from the National Qualification Structure

certificate A

a new “sub-diploma” level certificate

- stackable (small badges earn larger badges)
- motivator for learning
- usable in non-formal and formal settings

europass

Europass... since 2005, a portfolio for LLL

- essentially paper based
- 10 years later “not fit for purpose”

2018 May: New Europass Decision

2018 October: Europass Advisory Group

direction (Q4-2019)

A secure digital portfolio

- Europass in “the cloud”, also for badges
→ CV with credentials!

Export to Eures e.a.

Original 5 documents remain for now

direction (Q4-2019)

Central information portal

- Euroguidance
 - Ploteus
 - EQF
 - Skills Panorama
 - ...
- one “brand”

direction (after 2019)

Issuing services for organisations

open badges

- based on EU key competences?
- based on ESCO?

digital diploma's on blockchain?

- Europass Diploma supplement?



Dienst Uitvoering Onderwijs
*Ministerie van Onderwijs, Cultuur en
Wetenschap*

Thank you for your attention!